

Intelligent Robots for Space Applications

Dr. David Kortenkamp

NASA Johnson Space Center/Metrica Inc.

Houston TX 77058

kortenkamp@jsc.nasa.gov

<http://www.traclabs.com/~korten>

Motivation

- Planetary surfaces can be explored more cheaply and quickly
- Expensive and dangerous Extra Vehicular Activities (EVAs) by astronauts can be reduced
- Spin-off applications on earth

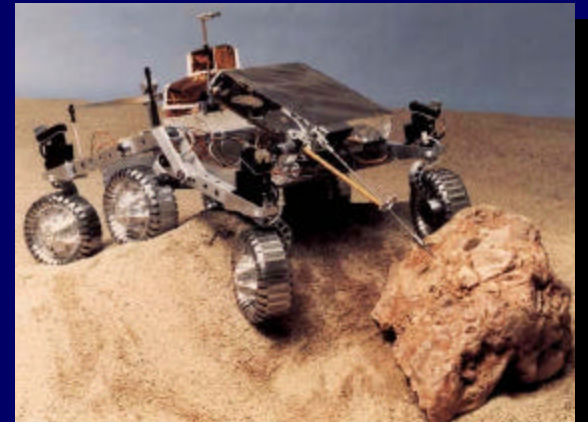

A Brief History of Intelligent Robots

- **Shakey (1966 - 1972)**
 - Sense, plan, act (SPA)
 - STRIPS planner (operators, pre and post conditions)
 - very slow!

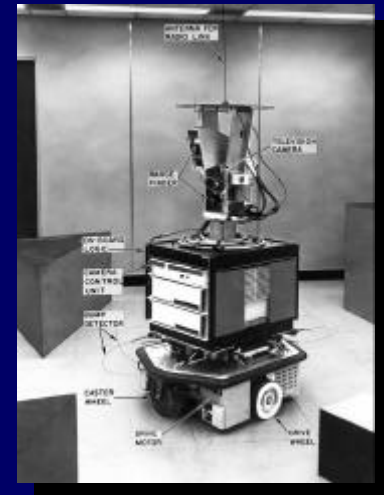

Rodney Brooks and Subsumption

- Subsumption architecture published in 1986
- No internal models: “The world is its own best model”
- Fast, alive!

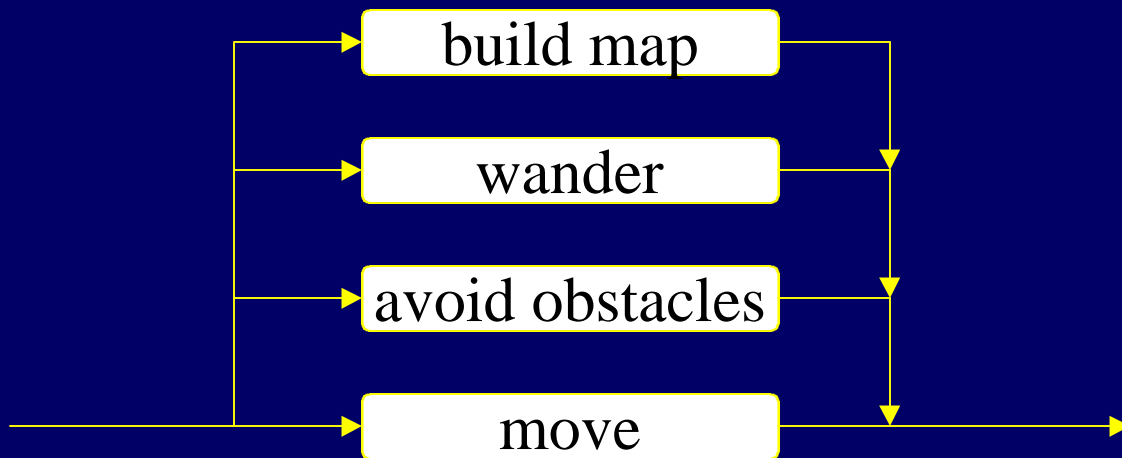

Hybrid Systems

- Desire to have robots that are both *reactive* and *deliberative*
- Combined subsumption and planning

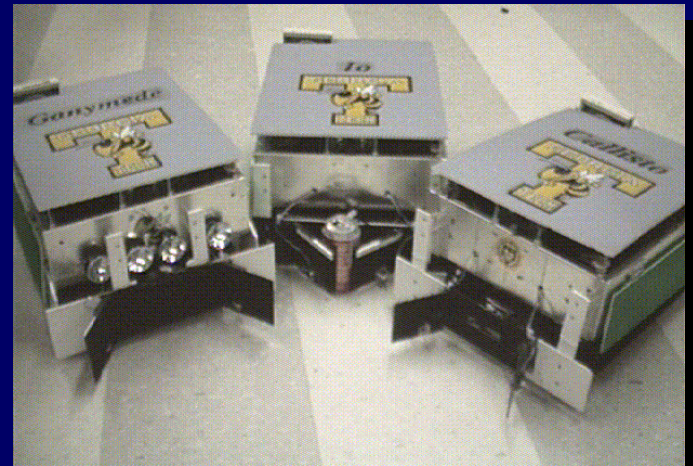
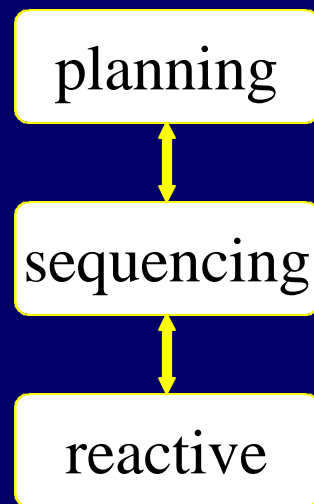

Probabilistic Robots

- Primarily concerned with mapping (localization) and navigation
- Try to determine most likely position of robot

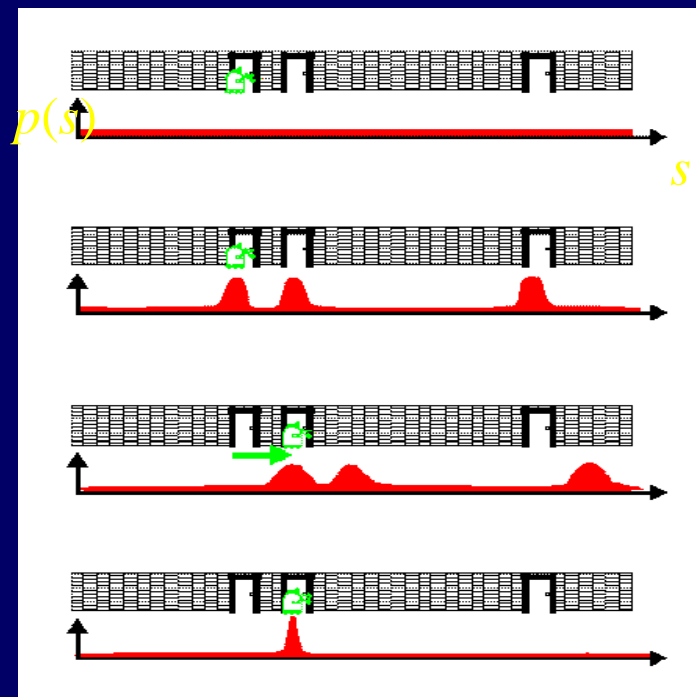

AAAI Robot Competitions

- 1992 in San Jose
 - find and approach 10 poles in large arena with stationary obstacles
- 1996 in Portland
 - navigate an office building
 - collect moving and stationary balls
- 2000 in Austin TX
 - serve hors d'oeuvres
 - search and rescue

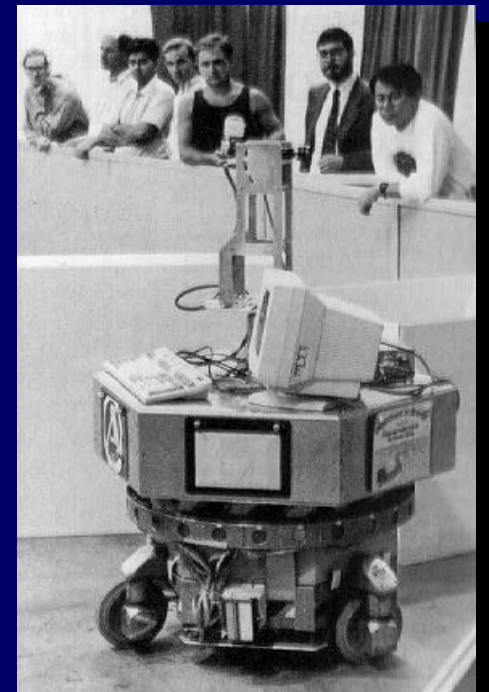

Key Areas in Robotics

- Mapping and navigation
 - obstacle avoidance
 - mapping
 - path planning
- Computer vision
 - stereo vision
 - color vision
- Architectures

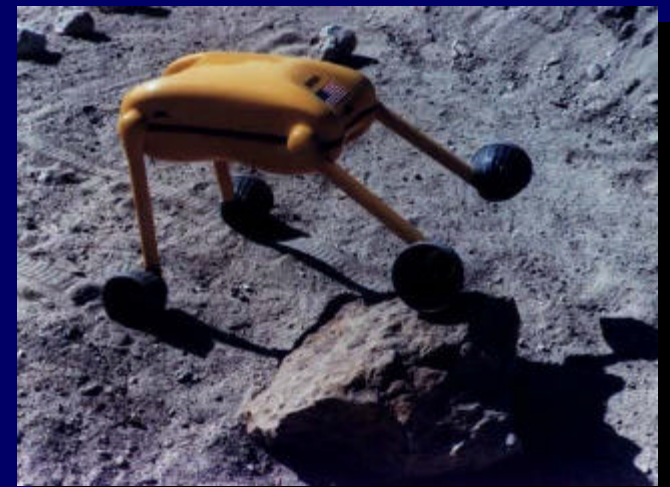

Obstacle Avoidance

- Sonar sensors

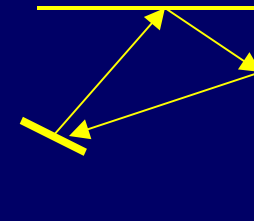
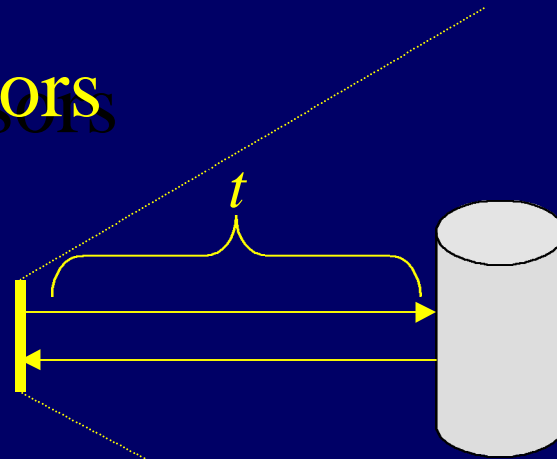

multiple reflections

- Certainty grids

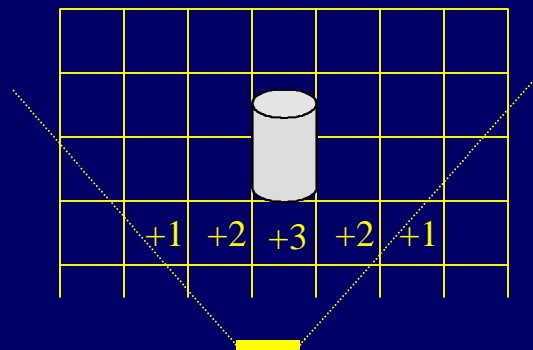

Mapping

- Topological mapping
 - distinctive places
 - connection graph
 - less need for accurate location
- Geometric mapping
 - spatial relationships maintained
 - uncertainties multiply

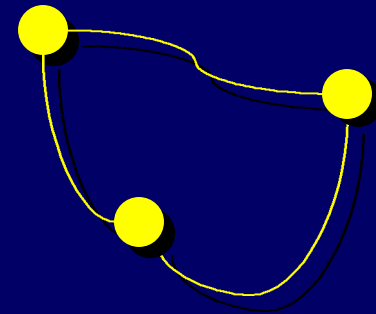

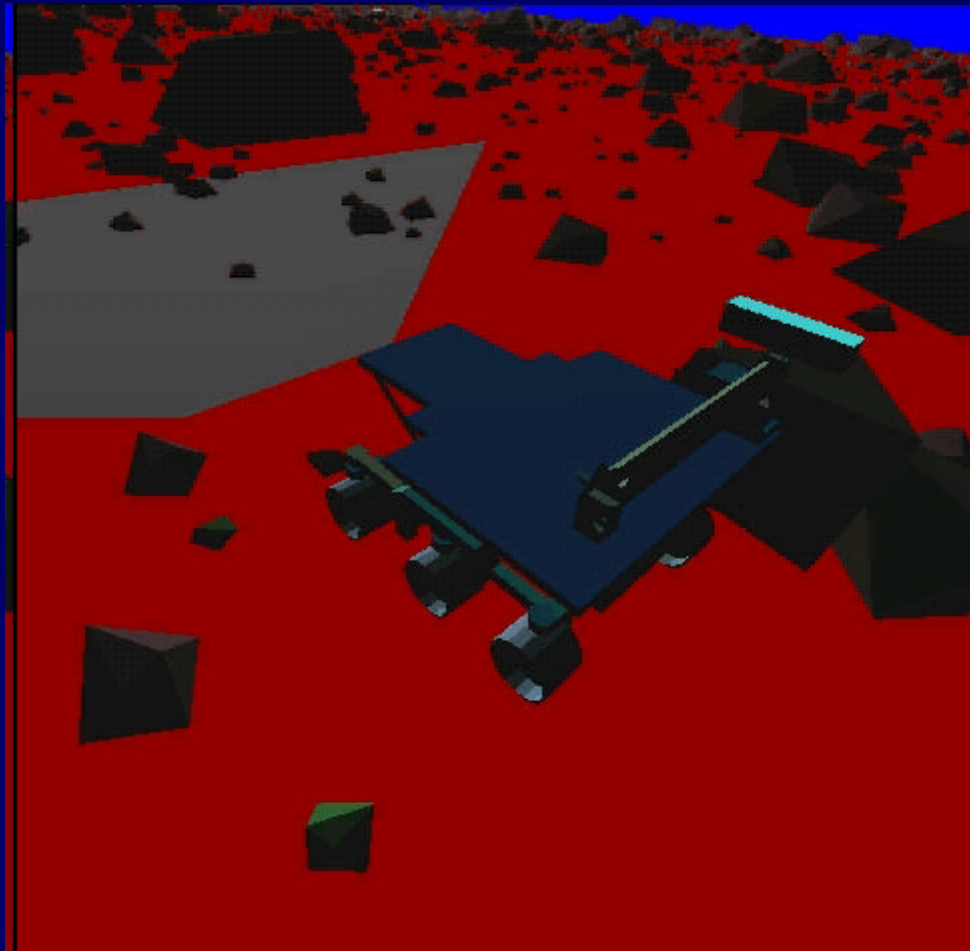

Dr. David Kortenkamp
NASA Johnson Space Center

Stereo Vision

- Two cameras at a fixed distance (*baseline*) from each other
- Different perspectives of two cameras (right and left) lead to relative difference between the location of the same object in the two images, which varies by distance.

$$\text{Distance} = \frac{\text{baseline} * \text{focal length}}{X_1 - X_2}$$



Color Vision

- Image composed of red, green and blue (RGB) components
- By knowing the color characteristics of an object (and normalizing for light) specific objects can be recognized
- Solid colors are easy
- Multiple colors use histograms

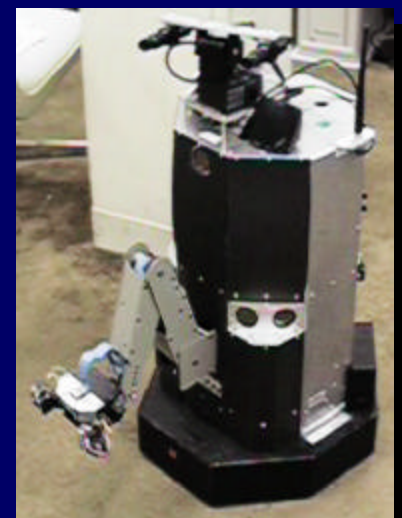

Architectures

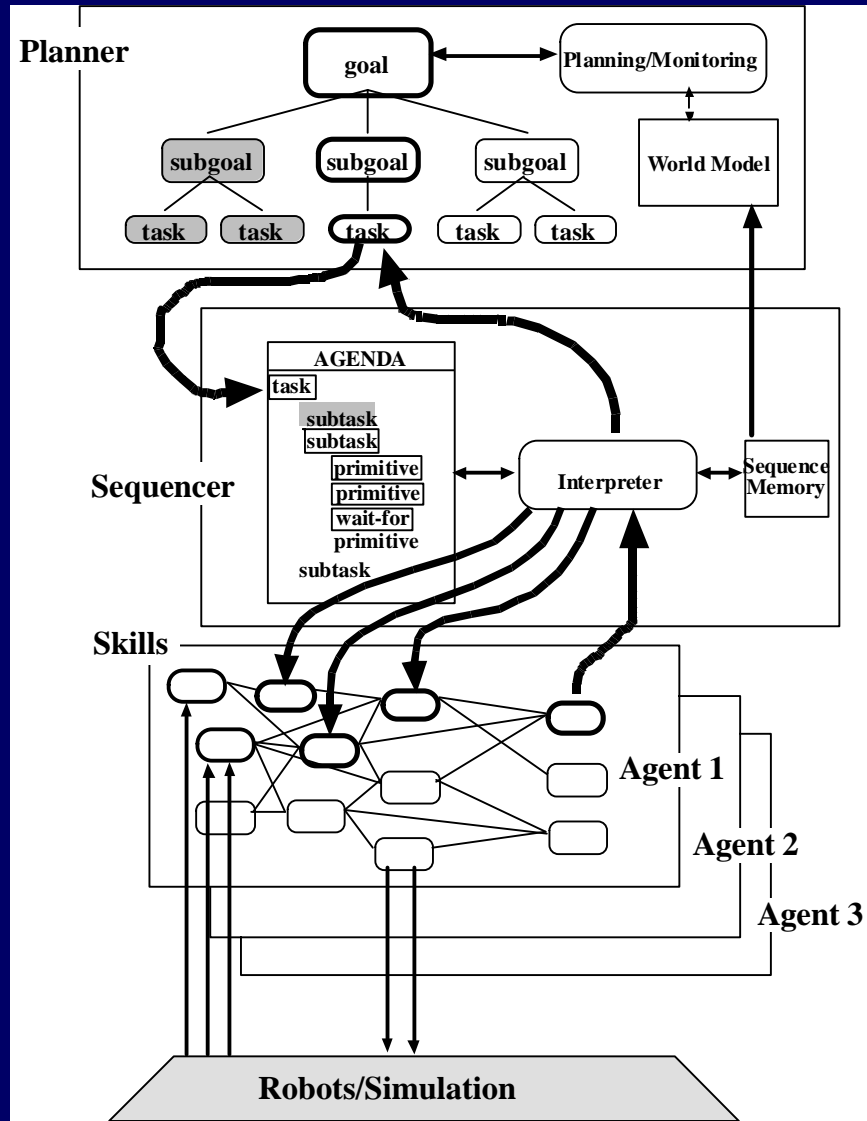

- **Planning**
 - responsible for time and resource constraints
- **Sequencing**
 - conditional activation of skill sets
- **Control**
 - skills provide reactive control of robot

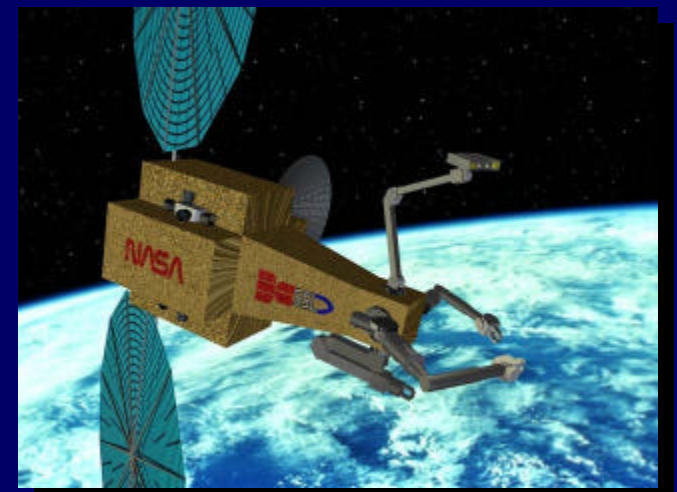

Planning example

```
(Operator replace-batteries
:purpose (state batteries replaced)
:agents (?robot ?human)
:constraints ((instance-of ?robot 'robot)
              (instance-of ?human 'human))
:preconditions ((state bay opened))
:plot (sequential
       (covers
        (monitor-batteries ?robot in-monitor)
        (display ?human monitored))
       (batteries ?robot are-replaced))
:effects ((state batteries replaced)))
```

Sequencing example

```
(define-rap (arm-move ?arm ?place)
  (succeed (and (arm-at ?arm ?where)
                (= ?where ?place))))
(method robot-move
  (context (and (LOA arm-move ?arm ?place ?loa)
                (= ?loa autonomous))))
  (primitive
    (enable (:arm_move (:place . ?place))
      (wait-for (arm-move-done ?arm ?place ?result)
        :succeed (arm-move ?result))
      (disable :above))))
(method human-move
  (context (and (LOA arm-move ?arm ?place ?loa)
                (= ?loa tele-operate))))
  (primitive
    (tell-user "move arm to ?place")
    (wait-for (arm-move-done ?arm ?place ?result)
      :succeed (arm-move ?result))))))
```

Intelligent Robots in Space

- Planetary rovers
 - exploration
 - preparation
- In-orbit operations
 - astronaut assistance
- Future applications
 - on-going NASA research



Rovers

- Sojourner (part of the Mars Pathfinder mission) was first mobile robot on Mars
- Simple on-board hazard avoidance (using laser ranging, imaging and internal sensors)
- Mostly up-linked targets on regular basis
- Some path planning



Future Rovers

- NASA to send two rovers to Mars in 2003
(will land in January 2004)
- Large (~130kg)
- 90 day mission, 100 meters each mission day

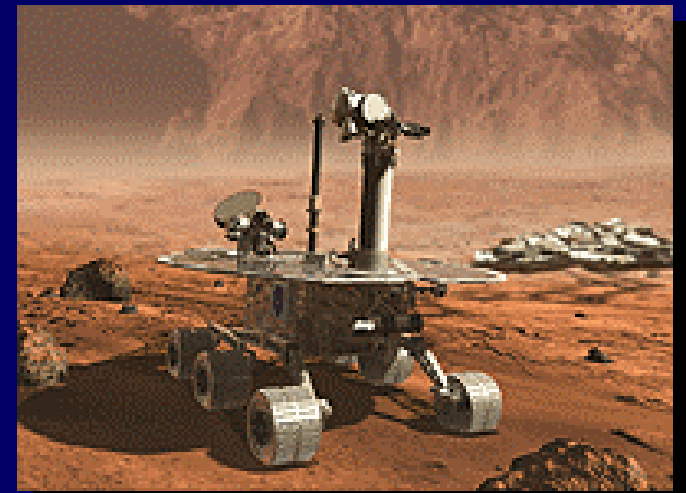

In-orbit operations

- **AERCam Sprint**
 - provides a moveable camera view
 - flew on STS-87 in 1997
 - no real autonomy
- **Shuttle Remote Manipulator**
 - not really a robot
 - no autonomy



Research Robots

- Robonaut
 - humanoid robot
 - teleoperated
- EVA Robotic Assistant
 - assists astronauts on Mars
 - fully autonomous
- Antarctica
 - meteorite search



Conclusion

- Robots require:
 - sensing (vision, range)
 - actuation
 - control
 - artificial intelligence
- Space robots becoming more capable and autonomous
- Robots beginning to become real

Further Reading

- *Mobile Robots and Artificial Intelligence: Case Studies of Successful Robot Systems*
 - David Kortenkamp, Robin Murphy, R. Peter Bonasso, editors
 - MIT Press or Amazon.com

